



VERTICAL MAX-S

Oven with top and lower heated cabinet



TECHNICAL INFORMATION

Reference	HMB AC 75
Fire up time ¹	45 min
Cooking temperature	250 - 350 °C
Initial charcoal load ¹	10 kg
Production*	70 kg/h
Charcoal load duration ²	7 h
Equivalent power*	3,5 kW
Exhaust rate	2800 m ³ /h
Net weight ³	493 kg
Crated weight ³	605 kg
Crates dimensions (WxDxH)	1) 900 x 800 x 1350 mm 2) 900 x 800 x 2050 mm

*Approximate data

1. Consult instruction manual
2. Will vary depending on quality of charcoal
3. Weight with accessories included

FEATURES

OUR CHARCOAL OVENS

The Mibrasa® oven is a closed grill designed and engineered in our workshops. Made from the best quality steel by expert hands, our grills are designed to satisfy even the most demanding chefs.

The technical specifications allow the user to accurately control the air flow through the grill, changing the intensity of the embers. This is an extremely efficient way of cooking and cuts down the amount of charcoal needed.

Mibrasa® charcoal ovens allow you to cook all types of foods retaining the natural flavors and bringing out a unique taste.

THE VERSATILITY OF MIBRASA® CHARCOAL OVENS

We have a wide range of high quality products and accessories allowing you to completely personalize your Mibrasa® charcoal oven, adapting it to your needs.

PAX PER SERVICE*



GRILL DIMENSION

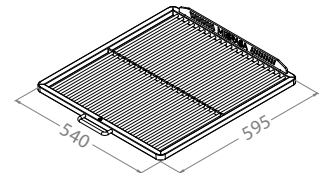

INCLUDED ACCESSORIES

- Firebreak-dissipating filter [FB-DF]
- Grill [GT75]
- Mibrasa tongs [TG]
- Poker [PK75]
- Grill brush [CEP]
- Ash shovel [PALA]

RECOMMENDED ACCESSORIES

- Extra grill [GT75]
- Removable grease collector [REG1P/2]
- Casters [WINOX]
- Consult catalogue for kitchenware and grillware

QUALITY GUARANTEE



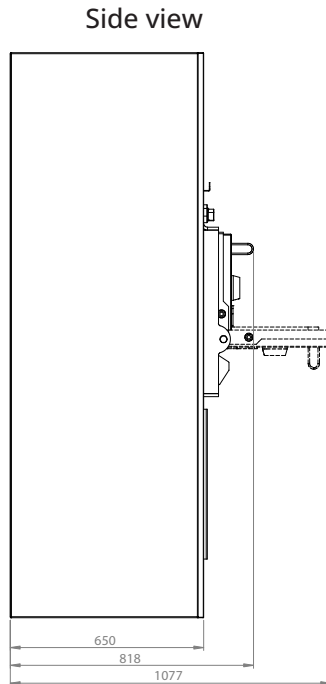
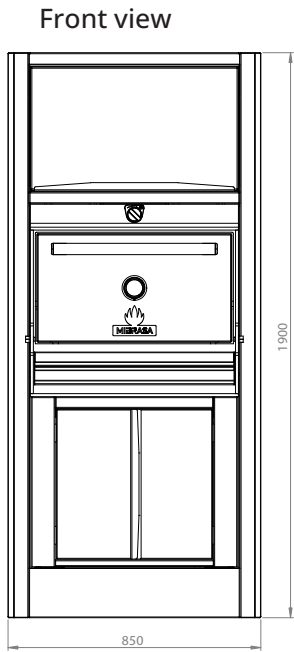

Option 1

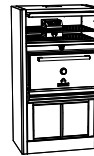

Option 2



CUSTOMIZE

DOOR COLOR



BLACK



RED



YELLOW



STAINLESS STEEL



BLUE

EDITION



GOLD



BLACK



COPPER



TITANIUM



SILVER



WOOD*

The Edition finishes are applied to the logos, door handle and the thermometer casing.

*Only on the door handle (logos and thermometer casing in silver)

Dimensions in mm

Revit drawings available on request at mibrasa@mibrasa.com

Total height option 2: 2141 mm

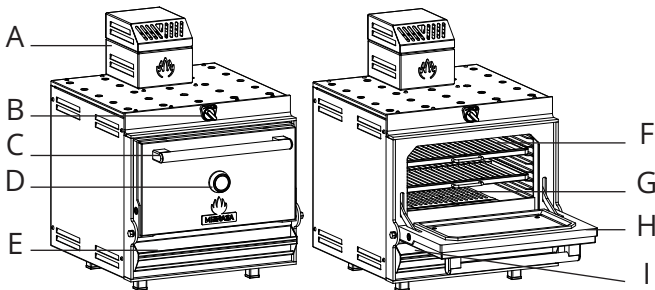

A	Firebreak-dissipating filter
B	Upper damper
C	Door handle
D	Thermometer
E	Lower damper/ash collector
F	Grills
G	Charcoal grids
H	Door
I	Grease collector

GASTORNORM CAPACITY

HEATING RACK (x2)

Compatible with Mibrasa GN.

Residual temperatures of the heating rack in the top cabinet approximately 150°C, based on the oven working at 300°C.

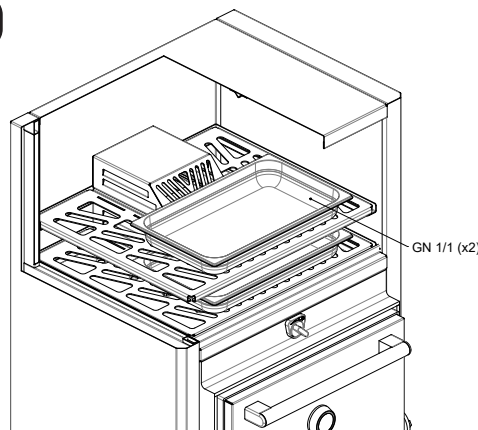

INSTALLATION GUIDELINES AND SAFETY STANDARDS

Recommended installation height	-
Clearances to construction/other appliances from oven	76 mm
Clearances of flammable materials from oven	300 mm
Clearance of workspace from front of the oven	1100 mm



It is recommended to use a lifting device to lift the oven and place on the countertop/cabinet. Consult oven instruction manual for further information.

Specifications and design are subject to change without notice.